

7. SPD Series (Shielded Type)

Applications

- Power supply for VTRs.
- Personal & Notebook computers.
- Smart Home Systems.
- Other various electronic appliances.

Features

- Compact, low profile with Rdc and large current.
- With magnetic shielded against radiation.
- Flat bottom surface allows reliable mounting onto the board.
- High power, high saturation inductors.



Inductance and Rated Current ranges

Part Series	Inductances range	Rated Current range
* SPD0628	1.0~1000μH	2.10~0.12A
* SPD0732	1.0~1000μH	2.40~0.20A (I _{rms}) ; 2.20~0.13A (I _{sat})
* SPD0745	1.0~1500μH	3.50~0.15A (I _{rms}) ; 4.00~0.10A (I _{sat})
* SPD1045	1.0~1500μH	12.00~0.40A (I _{rms}) ; 7.80~0.22A (I _{sat})
* SPD1255	6.0~1500μH	4.90~0.48A (I _{rms}) ; 3.60~0.29A (I _{sat})
* SPD1265	2.0~150μH	8.00~0.80A (I _{rms}) ; 10.00~1.00A (I _{sat})
* SPD1275	1.2~330μH	10.40~0.88A (I _{rms}) ; 13.00~1.10A (I _{sat})

(Dimension data (Refer to Fig. 1))

Characteristics

Test Frequency : 1.0KHz 0.5V

- Saturation Rated Current (I_{sat}) : The current when the inductance becomes 30% lower than its nominal value.
 - Temperature Rated Current (I_{rms}) : The actual current when the temperature of coil becomes to T=40 . (T_a=25)
- Operating temperature range : -40 ~+125 .

Test equipment :

L: HP4284A LCR meter.

DCR: Milli-ohm meter.

Electrical specifications at 25 .

Part Numbering System

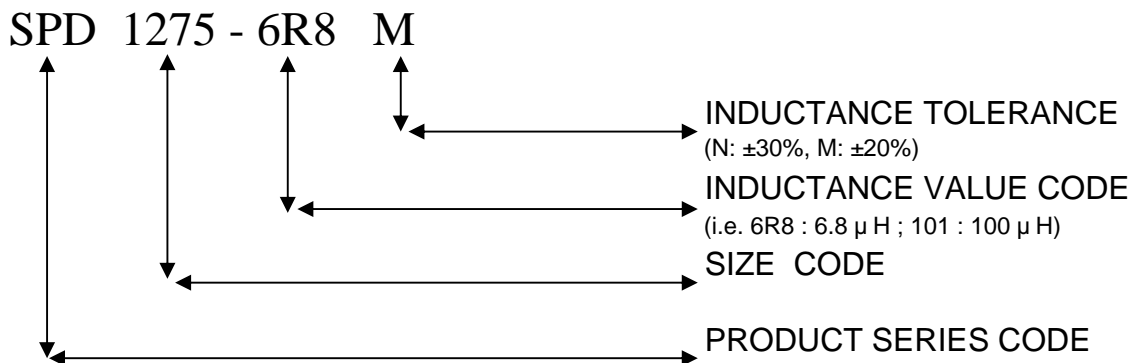

7. SPD Series (Shielded Type)

Dimensions (mm)

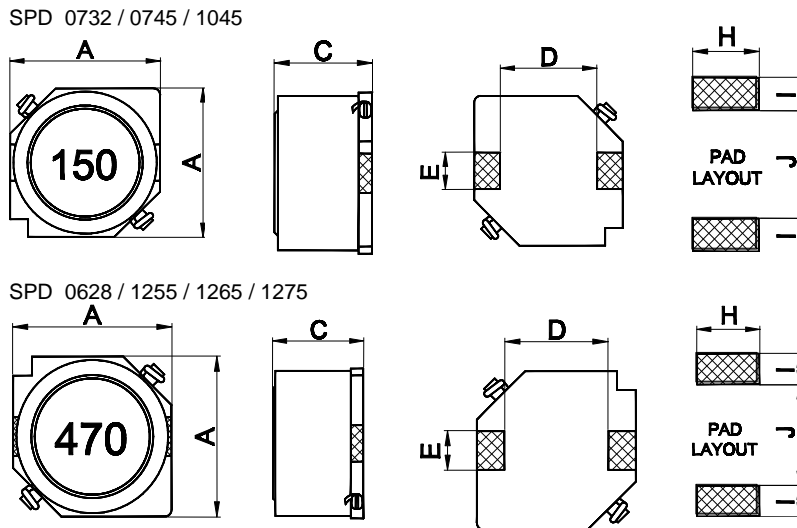

Fig. 1

Series	A	C	D	E	H	I	J
SPD0628	6.00±0.20	2.80±0.20	4.00	2.00	2.20	1.50	4.00
SPD0732	7.00±0.20	3.20±0.20	4.00	2.00	2.20	1.50	4.00
SPD0745	7.00±0.20	4.50±0.30	4.00	2.00	2.20	1.50	4.00
SPD1045	10.10±0.30	4.50±0.30	6.00	3.00	3.20	2.50	5.60
SPD1255	12.50±0.30	5.50±0.35	8.60	3.00	3.20	2.50	8.60
SPD1265	12.50±0.30	6.50±0.35	8.60	3.00	3.20	2.50	8.60
SPD1275	12.50±0.30	7.50±0.35	8.60	3.00	3.20	2.50	8.60

7. SPD Series (Shielded Type)

Electrical Characteristics

SPD 0628 TYPE

Inductance Value Code	Tol.	L (μH)	Test Condition	DC Resistance (Ω) ±20%	Rated DC Current (A) Max.
1R0	M	1.0	1KHz, 0.5V	0.024	2.10
1R5	M	1.5	1KHz, 0.5V	0.025	2.00
1R8	M	1.8	1KHz, 0.5V	0.026	1.95
2R2	M	2.2	1KHz, 0.5V	0.022	1.90
2R8	M	2.8	1KHz, 0.5V	0.025	1.80
3R5	M	3.5	1KHz, 0.5V	0.030	1.70
4R1	M	4.1	1KHz, 0.5V	0.035	1.65
4R7	M	4.7	1KHz, 0.5V	0.036	1.60
6R8	M	6.8	1KHz, 0.5V	0.052	1.50
8R2	M	8.2	1KHz, 0.5V	0.061	1.35
100	M	10	1KHz, 0.5V	0.068	1.30
120	M	12	1KHz, 0.5V	0.081	1.10
150	M	15	1KHz, 0.5V	0.100	1.00
180	M	18	1KHz, 0.5V	0.129	0.87
220	M	22	1KHz, 0.5V	0.120	0.77
270	M	27	1KHz, 0.5V	0.179	0.71
330	M	33	1KHz, 0.5V	0.180	0.69
390	M	39	1KHz, 0.5V	0.239	0.61
470	M	47	1KHz, 0.5V	0.270	0.59
560	M	56	1KHz, 0.5V	0.330	0.51
680	M	68	1KHz, 0.5V	0.390	0.50
820	M	82	1KHz, 0.5V	0.459	0.43
101	M	100	1KHz, 0.5V	0.620	0.42
121	M	120	1KHz, 0.5V	0.659	0.33
151	M	150	1KHz, 0.5V	0.919	0.30
181	M	180	1KHz, 0.5V	1.049	0.28
221	M	220	1KHz, 0.5V	1.219	0.25
271	M	270	1KHz, 0.5V	1.598	0.22
331	M	330	1KHz, 0.5V	1.789	0.21
391	M	390	1KHz, 0.5V	2.289	0.20
471	M	470	1KHz, 0.5V	2.698	0.18
561	M	560	1KHz, 0.5V	3.198	0.16
681	M	680	1KHz, 0.5V	4.310	0.15
821	M	820	1KHz, 0.5V	4.698	0.13
102	M	1000	1KHz, 0.5V	5.790	0.12

Test Frequency : 1.0KHz 0.5V

1. Saturation Rated Current (I sat) : The current when the inductance becomes 30% lower than its nominal value.

2. Temperature Rated Current (I rms) : The actual current when the temperature of coil becomes to T=40 . (Ta=25)

Operating temperature range : -40 ~+125 .